



SUBMITTAL DATA – ROOFTOP PACKAGE UNIT

CTPU-C-240-C-MM-1

SCROLL COMPRESSOR

Job:	Engineer:
Location:	Architect:
Schedule No.:	Date:
System Designation:	For: <input type="checkbox"/> Reference <input type="checkbox"/> Approval <input type="checkbox"/> Review <input type="checkbox"/> Construction

FEATURES

- Horizontal supply and return air.
- Durable construction with pre-painted exterior cabinet with 1000 hours salt spray test
- Reliable scroll compressor.
- Adjustable pulley (indoor Fan)
- Compatible with 3rd party 24V thermostat
- Easy to installation
- Cooling Only
- System self-diagnostic
- Wired Controller CTVS-C-KJR25B included

Model		CTPU-C-240-C-MM-1	
Cooling Performance Data	Total Cooling Capacity	Btu/h	240,000
	Sensible Cooling Capacity	Btu/h	171,599
	Cooling Power Input	kW	21.90
	EER		10.96
	Cooling Outdoor DB	°F	95
	Cooling Indoor DB/WB	°F/°F	80 / 67
	Supply Air Temp. DB/WB	°F/°F	55.6 / 67
Supply Fan Performance Data	Supply Air Flow	CFM	8,580
	Supply Motor RPM		1,730
	ESP	in.wg	0.48
	Supply Motor Power	HP	5.51
	Fan Type/Qty.		Centrifugal / 2
	Supply Motor Qty.		1
	Drive Type		Belt
General Data	Refrigerant Type		R410a
	Compressors Type/Brand		Scroll/Copeland
	No. of Compressors		2
	No. of Stages		2
	Throttle Device		Capillary
	Net Dimension WxHxD	inch	65.8" x 49.1" x 86.3"
	Package Dimension WxHxD	inch	66.7" x 50.6" x 87.1"
	Net Weight	Lbs	1,474
	Gross Weight	Lbs	1,540
Electrical Data	Sound Pressure Level	dB(A)	78.3
	Power Supply		220V,3Ph,60Hz
	MCA	Amp	98.6
	MOP	Amp	121.5
	Compressor RLA	Amp	30.9A +30.9A
	Compressor LRA	Amp	240A + 240A
	Supply Fan FLA	Amp	15.1
	Condenser Fan FLA	Amp	6.99A + 6.99A
Condenser Fan Motor Power	HP	2.51hp + 2.51hp	



Wired Controller CTVS-C-KJR12B (Included)

OPTIONAL ACCESSORIES (not included)

- Wired Controller CTVS-C-KJR-29B
- Wired Controller CTVS-C-25B
- Central Control Interface NIM01
- Central Controller CTVS-C-CCM30
- G2 Filter CTVS-C-KQGLW-700A

Note – Due to Comfort Time ongoing commitment to quality, specifications, ratings and dimensions are subject to change without notice and without incurring liability. Improper installation, adjustment, alteration, service, Maintenance and operation may cause properly damage on personal injury. Installation, service and operation must be performed by a qualified installer, servicing and operation agency.

DIMENSIONAL DRAWINGS - (MM)

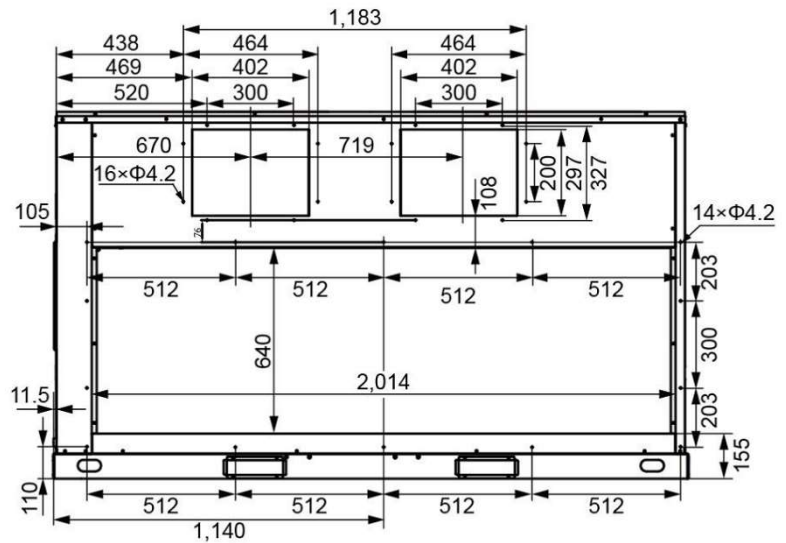
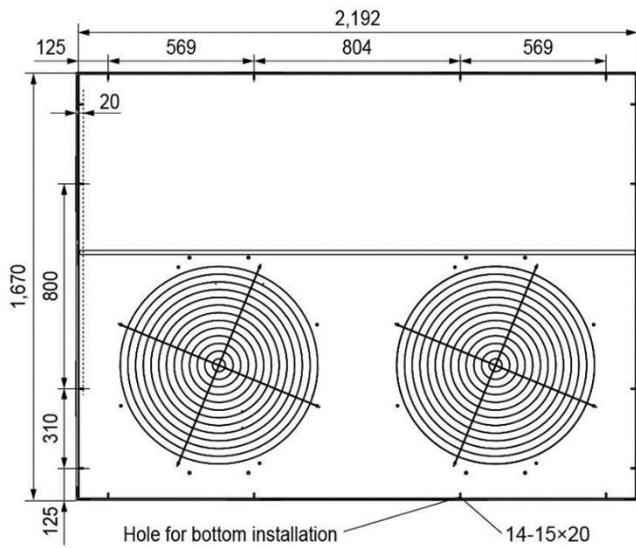
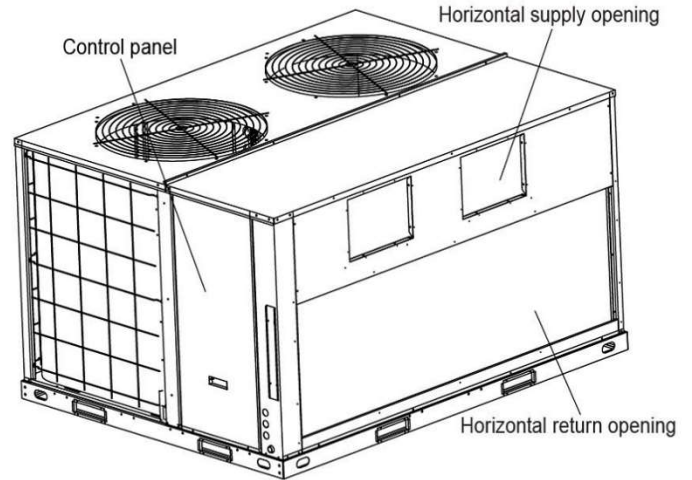
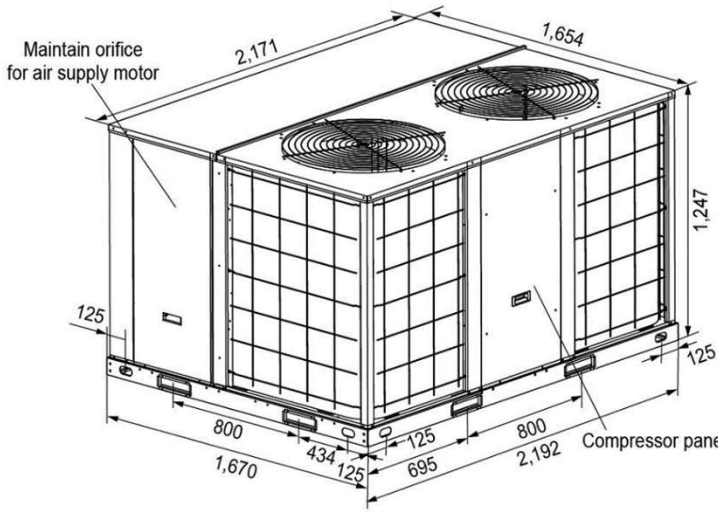

Note – Due to Comfort Time ongoing commitment to quality, specifications, ratings and dimensions are subject to change without notice and without incurring liability. Improper installation, adjustment, alteration, service, Maintenance and operation may cause property damage or personal injury. Installation, service and operation must be performed by a qualified installer, servicing and operation agency.